



## Generative design

Optimize shapes to achieve design goals

Generative design is a process that determines the most efficient shape based on defined material, constraints and stresses. Also known as topology optimization, generative design takes modeling from “computer-aided” to “computer-driven” – with resulting forms that look very much like nature.

## Generative design: How is it different?

With **traditional design**, you typically create multiple concepts, then evaluate and optimize one or more, based on your design goals.

With **generative design**, you start with your design goals, and algorithms automatically generate optimized design options for achieving them.

You can create multiple iterations of designs, identifying options to meet various goals (i.e. weight reduction). The process often results in organic forms similar to those seen in nature.



## Design with goals in mind

Generative design is meant to create models that meet your design goals and conform to constraints, with lighter components and minimal material usage. The process can also drive innovation, by breaking through our preconceived notions of what a design should look like and creating shapes that are optimized for purpose. All the user needs to do is guide the software in the workspace – defining fixed points or inputs, loads and materials.



## Solid Edge for generative design

Generative design in Solid Edge integrates advanced topology optimization within the Solid Edge 3D modeling toolkit, helping designers to create lighter components, minimize material waste in downstream manufacturing, and also create highly customized designs well-suited for casting or high-resolution 3D printing. Generative design in Solid Edge is unique in that it results in “ready-to-print” surface quality.

Obtain a reduced-mass geometric solution of a specific material optimized within a design space, accounting for permissible loads and constraints. Immediately manufacture the body via additive processes, use it as a core for mold base design, or use the Solid Edge toolkit to further refine the shape for traditional manufacturing.

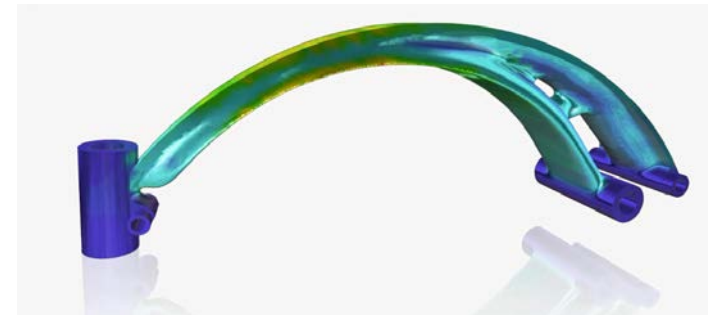

## How does it work?

Generative design is accomplished through a simple workflow, where the user defines constraints and conditions, and the system automatically provides resulting options.

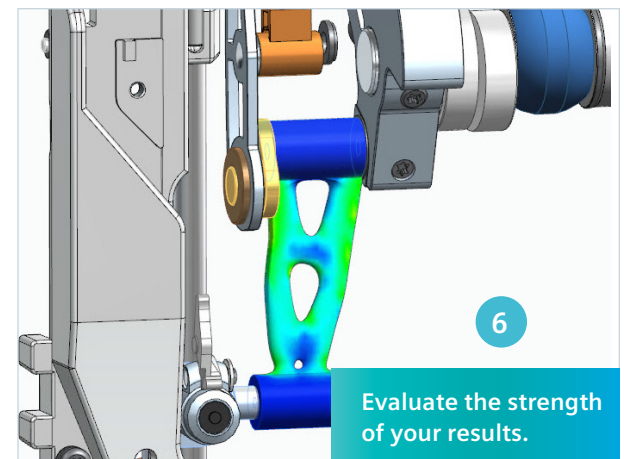
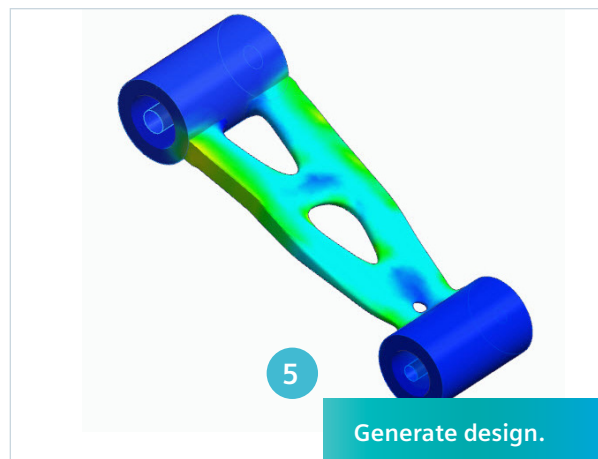
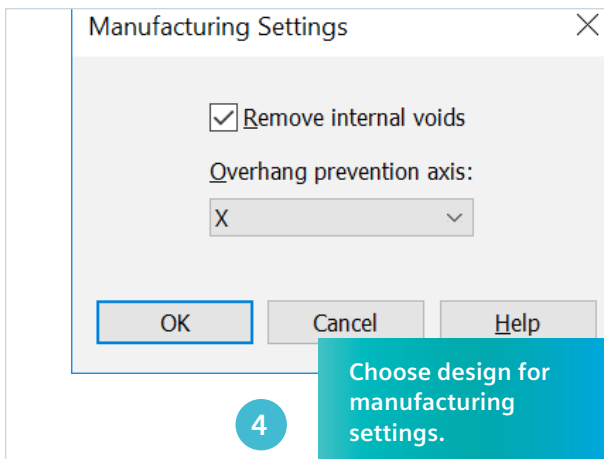
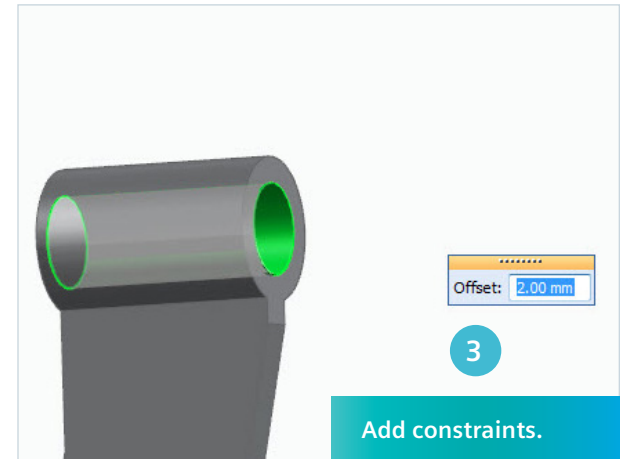
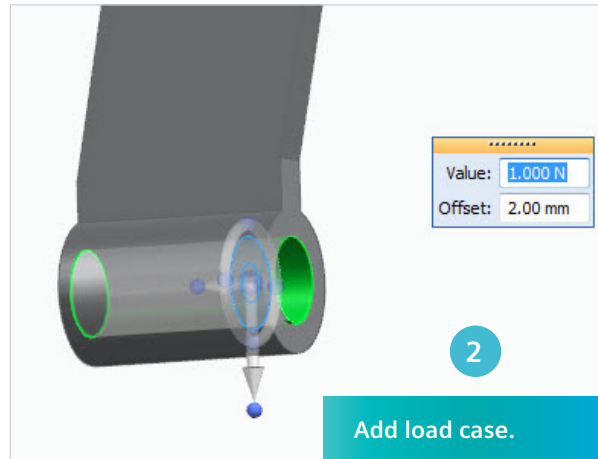
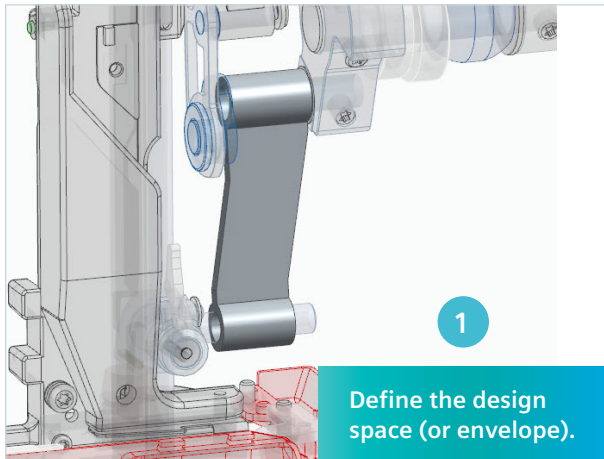

## Moving to manufacturing

With resulting designs that can be incredibly complex, how do you make them real? Generative designs are well suited for 3D printing, can be further refined for traditional manufacturing.

### Ready for 3D printing

The parts resulting from the generative iteration are ready for manufacturing via additive processes. Today's high-resolution 3D printers can handle the complex shapes, shortening your new product time-to-market or speeding production of replacement parts. The surface quality of the model is ready to print without any additional modeling or modification.

### Evolve using convergent technology

The optimized components from generative design can be further modified with convergent modeling. The meshed results are seamlessly integrated into the normal model editing process, allowing you to get to your final design quickly.

The models created through generative design can be used in assembly models alongside traditional b-rep models, and can be placed onto drawing sheets.

## Want to learn more?

Visit: [www.siemens.com/plm/generative](http://www.siemens.com/plm/generative)

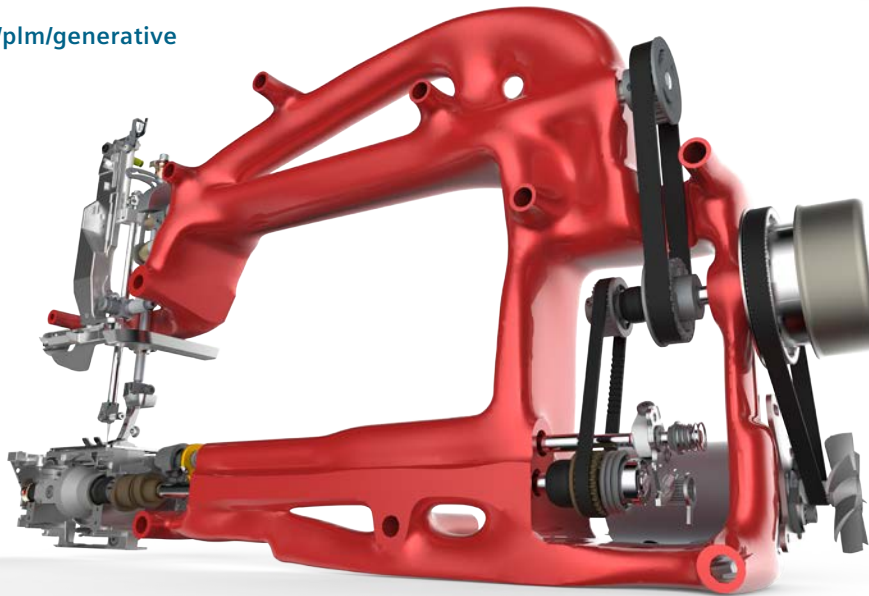

Siemens PLM Software  
[www.siemens.com/plm](http://www.siemens.com/plm)

Americas +1 314 264 8499  
Europe +44 (0) 1276 413200  
Asia-Pacific +852 2230 3308

© 2017 Siemens Product Lifecycle Management Software Inc. Siemens and the Siemens logo are registered trademarks of Siemens AG. D-Cubed, Femap, Fibersim, Geolus, GO PLM, I-deas, JT, NX, Parasolid, Solid Edge, Syncrofit, Teamcenter and Tecnomatix are trademarks or registered trademarks of Siemens Product Lifecycle Management Software Inc. or its subsidiaries in the United States and in other countries. All other trademarks, registered trademarks or service marks belong to their respective holders.

63757-A10 11/17 A